



LS212

High Output
Dual 12-inch
Bass Reflex
Subwoofer

- Specifically designed to accompany and complement DML500 and DML500A Distributed Mode Speakers
- 127 dB of sustained output; 130 dB peak
- High output subwoofer system, bass reflex port design employing asymmetrical acoustic chambers
- Dual 12-inch high output, low frequency transducer with 3-inch (100 mm) inside/outside, epoxy-baked, high temperature, voice coil assembly with neodymium magnetic structure
- Professional 16-ply birch construction with wear resistant polymer coating
- Can be used in single, dual and quad configurations
- 16 integrated M10 attachment points
- Two recessed handles for simplified handling and carrying
- M20 Top hat for pole mounting applications
- Acetyl copolymer, high impact, low friction feet are located on bottom allowing lock-in and easy cabinet movement
- Scalable for multi-unit installations

Applications

- Specifically designed to accompany and complement the DML500 and DML500A Distributed Mode Loudspeakers to create a true full range system
- Fixed installations such as
 - Churches
 - Educational Facilities and Gymnasiums
 - Performing Arts Centers
 - Government Facilities
 - Immersive Venues

We designed the LS212 to seamlessly interface with our DML500 and DML500A Distributed Mode Loudspeakers. This high output subwoofer delivers impressive, tight low frequencies that blend perfectly with our DML speakers: for churches, clubs, performance venues and other AV applications it is an impressive compliment to our 85Hz-24kHz offerings.

The secret is an asymmetrical-chamber that focuses and synchronizes the two 12-inch direct radiating transducers. It enables the LS212 to produce high sound pressure levels with tight dynamics and musical reproduction of very low frequencies. Two 12" woofers sport massive vented magnets and 3" epoxy-baked copper voice coils. Power handling is a robust 2400 W peak and 800 W continuous.

A perfect companion to our DML speakers, the LS212's focused bass is sure to impress your audience.



LS212 System	
Frequency Range (-10dB)	40Hz – 300kHz
Frequency Response(-6dB)	45Hz – 120Hz
System Sensitivity	97dB
Rated Maximum SPL	130dB (peak)
System Nominal Impedance	4 ohms
Power Handling	
Continuous / Program / Peak	800W/1600W/2400W
Recommended High Pass Filter	40Hz Butterworth 4 th Order
Recommended Low Pass Filter	110-130Hz (user defined)
Driver	
Low Frequency Transducers	12-inch x 2
Voice Coil Diameter	75 mm
Voice Coil Winding Wire	Copper-clad Aluminum
Magnetic Motor	Neodymium
Design	
Acoustic Design Principle	Asymmetrical Dual Chamber Band Pass 6 th Order
Physical	
Outer Dimensions (H x W x D)	26.6" x 14.9" x 23.8 676 mm x 378 mm x 605 mm
Weight	70 lbs / 31.75 kg
Hardware Attachment	
Internal M10 "L" brackets	16 locations
Pole Mount	Top Mount M20
Shipping Wt. & Dimensions	
Shipping Weight	93 lbs / 42.3 kg
Shipping Dimensions	31.5" x 21" x 33" 850 mm x 840 mm x 840 mm

LS212 High Output Dual 12-inch Bass Reflex Subwoofer



Acoustic Response

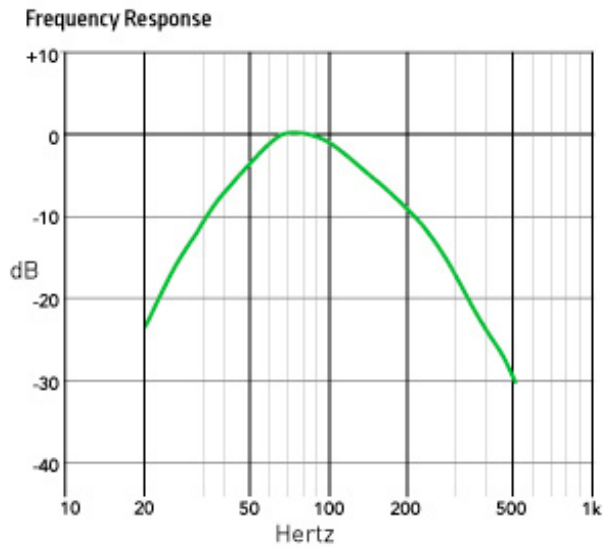

Measured using ground plane technique, microphone placed at 2 meters.

Recommended Filtering/Crossover: The following are the initial recommended acoustic filters as implemented for the LS212 ground plane measurement.

- High Pass - Butterworth 4th Order (24dB) @ 40Hz
- Peaking Filter - 40Hz / Q of 1.2 / Gain of 5dB
- Low Pass Filter - Butterworth 4th Order (24dB) @ 110Hz

Accessories - FlatPanel manufactures a variety of accessories and installation solutions for the LS212 allowing for seamless system integration.

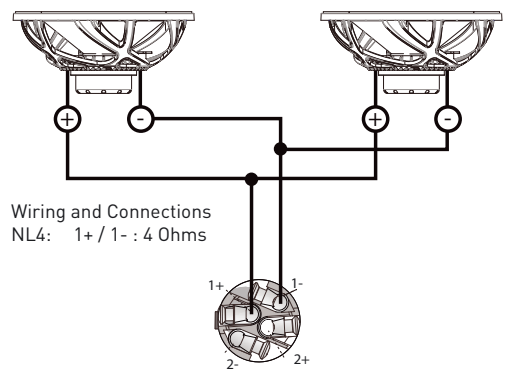
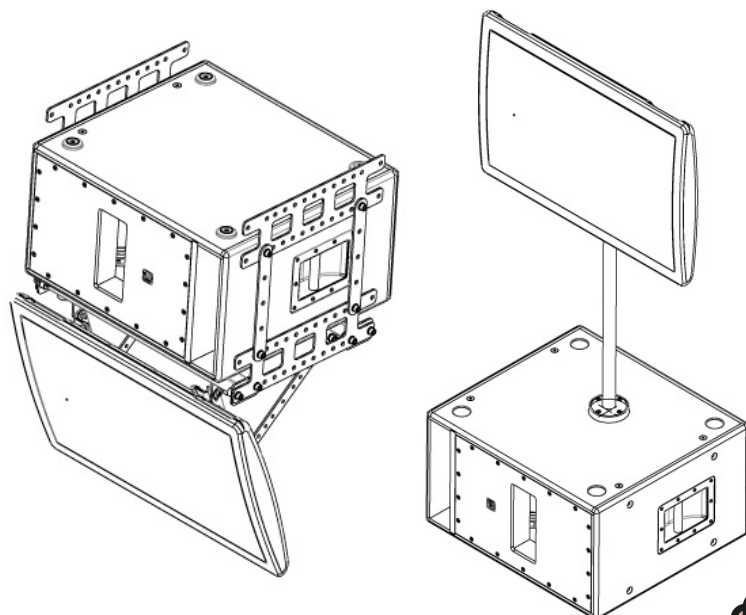
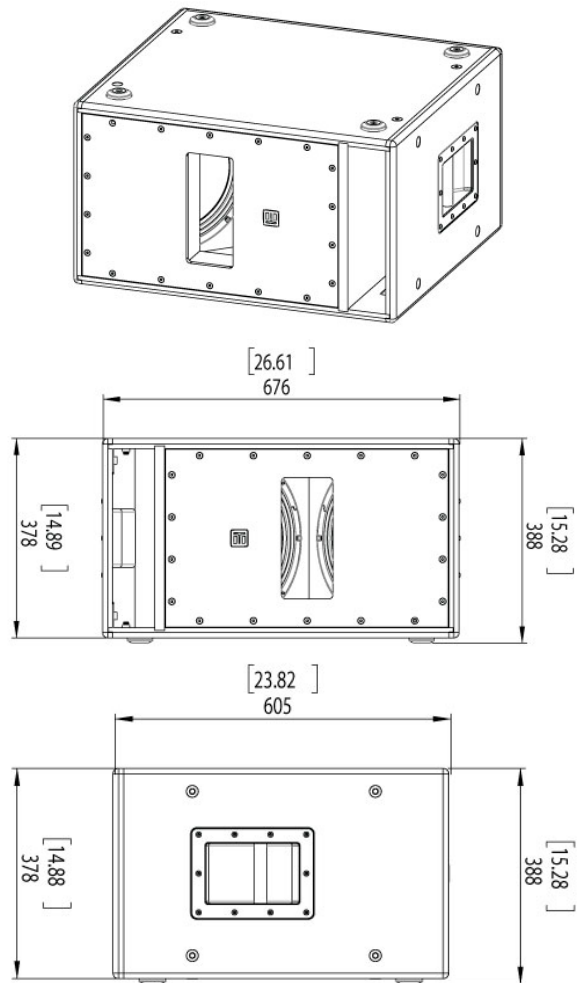

350 West Main Street, Unit C
 Los Gatos, CA 95030
 408.457.4371
www.FlatPanelAudio.com