

FlatPanel Audio

LS118

High output single 18-inch bass reflex subwoofer

Specifically designed to accompany and complement our DML500 and DML500A loudspeakers

- High output subwoofer system, bass reflex, semi horn-loaded port design
- Can be used in single, dual, and quad configurations
- Scales into dual and quad systems

Details that make it professional

- Professional 16-ply birch construction with wear-resistant polymer coating
- Four recessed handles for simplified handling and carrying
- Acetyl copolymer, high impact, low friction feet are located on the bottom to allow lock-in and easy cabinet movement

Where our DML500 loudspeaker leaves off, the LS118 takes over

Remarkably compact, this high output subwoofer delivers impressive, tight low frequencies that blend perfectly with our full-range speakers.

With an 18" direct radiating transducer, the LS118 produces high sound pressure levels with fast dynamics and musical reproduction of very low frequencies.

Its 18-inch woofer is armed with massive vented magnets and 4" copper voice coil. Power handling is an impressive 3500W peak and 1200W continuous.

As a companion to our DML500 and DML500A loudspeakers, or as a tight, focused bass source for portal PA systems, the LS118 will impress your audience.

The LS118 is an impressive complement to our DML500 and DML500A loudspeakers

Applications: fixed installations such as:

- | | |
|-------------------------|-----------------------------------------------|
| Churches | Government facilities |
| Educational facilities | Immersive venues |
| Gymnasiums | Portable PA applications, such as wedding DJs |
| Performing arts centers | |



LS118 system (single)

Frequency range (-10dB) 30Hz – 150Hz

Frequency response (-6dB) 36Hz – 100Hz

System sensitivity 100 dB

Rated maximum SPL 138dB (peak)

System nominal impedance 8 ohms

LS118 system (quad)

Frequency range (-10dB) 30Hz-150kHz

Frequency response (-6dB) 36Hz-100kHz

Rated maximum SPL 144dB (peak)

System nominal impedance 8 ohms

Power handling

Continuous /Program /Peak 1200W/2400W/3500W

Suggested high pass filter 32Hz Butterworth 4th order

Suggested low pass filter 100-120Hz (user defined)

Driver

Low frequency transducer 18-inch woofer

Voice coil diameter 100mm

Voice coil winding wire Copper-clad aluminum

Magnetic motor Neodymium

Design

Design principle Bass reflex with horn-loaded port

Hardware attachment

Internal M10"L"brackets 16 locations

Pole mount Top mount M20

Physical

Outer dimensions (H x W x D) 28 in x 25 in x 30 in
700 mm x 622 mm x 763 mm

Weight 114 lbs / 51.7 kg

Shipping dimensions (H x W x D) 34 in x 33 in x 33 in
850 mm x 840 mm x 840 mm

Shipping weight 134 lbs / 60.8 kg

FlatPanel Audio continually engages in research related to product improvement. Specifications are subject to change without notification.

FlatPanel Audio LS118

High output single 18-inch bass reflex subwoofer

Frequency response

Measured using ground plane technique, microphone placed at 2 meters.

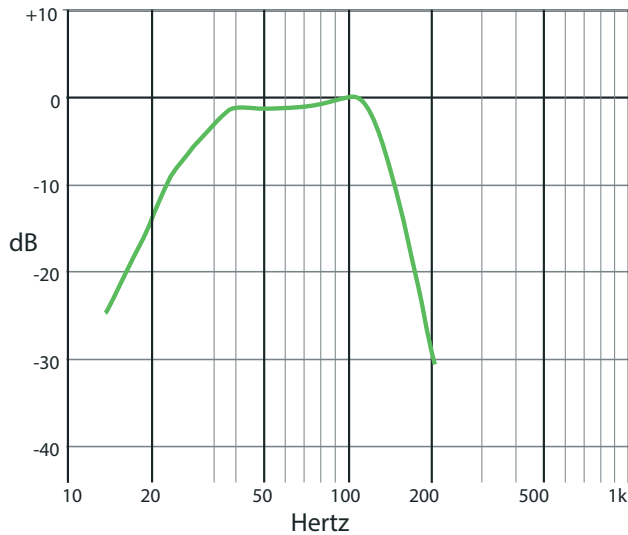

Suggested filtering/crossover

The following are the initial acoustic filters as implemented for the LS118 ground plane measurement:

High pass - Butterworth 4th order (24 dB) @ 30Hz

Peaking filter - 35Hz / Q of 1.2 / Gain of 6 dB

Low pass filter - Butterworth 4th order (24 dB) @ 100Hz

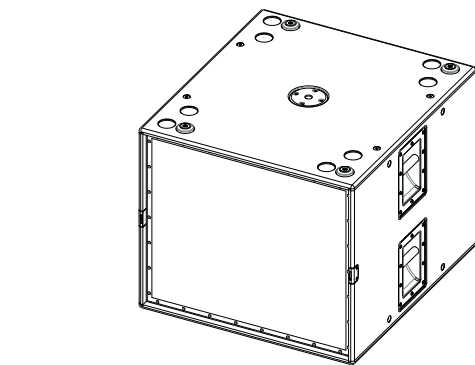
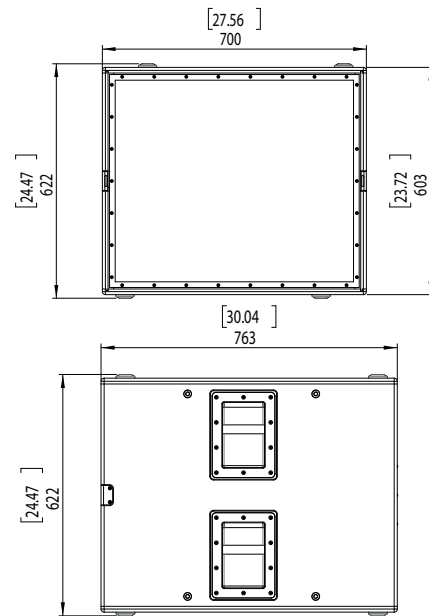

Dual Vertical Stack

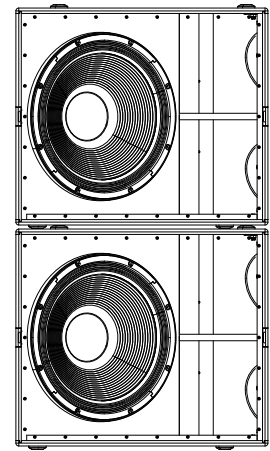

Quad Stack

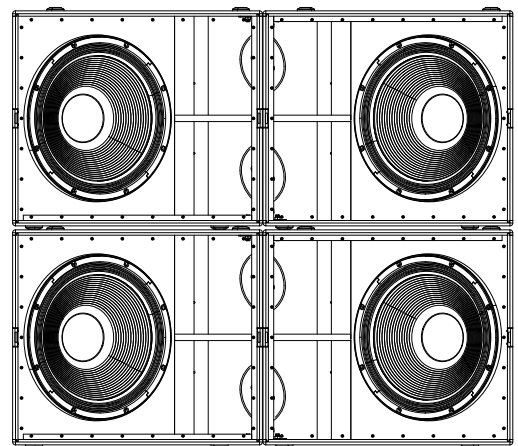

Dual Horizontal Stack

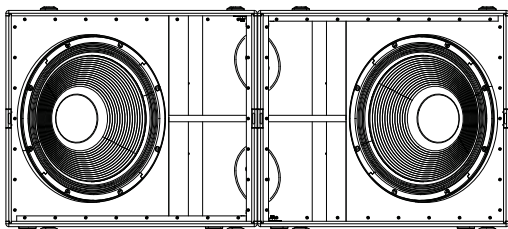

Accessories

FlatPanel Audio manufactures a variety of accessories and installation solutions for the LS118, allowing for seamless system integration.



FlatPanel Audio, LLC
350 West Main Street, Unit C
Los Gatos, CA 95030 USA
408.457.4371
www.FlatPanelAudio.com